

- ACCESSORI PER SMONTAGOMME ALTO DI GAMMA • ACCESSORIES FOR TOP LINE TYRE CHANGERS
- ZUBEHÖR FÜR TOP-REIFENMONTIERMASCHINEN • ACCESSORIES POUR DÉMONTE-PNEUS HAUT DE GAMME
- ACCESORIOS PARA DESMONTADORAS TOP DE GAMA

TOP LINE TYRE CHANGER accessories



Montaggio in fabbrica
Factory assembled
Werkseitig montiert
Montage en usine
Montaje en fábrica

Fare riferimento al listino prezzi per i codici degli smontagomme dove utilizzare ogni accessorio.
See pricelist for tyre changer reference applicability for each accessory.
Siehe Preisliste für den genauen Zubehöreinsatz auf Montiermaschinentyp.
Voir le tarif pour les références des démonte-pneus ou utiliser chaque accessoir.
Ver la lista de precios para las referencias de las desmuntadoras donde utilizar cada accesorio.



G1000A113
Utensile di montaggio superiore.
Upper tool.
Obere Montagekopf.
Outil supérieur.
Util superior.



G1000A117
Utensile di montaggio superiore.
Upper tool.
Obere Montagekopf.
Outil supérieur.
Util superior.



G1000A71K (5 x kit)

Kit tastatori.
Rim feeler kit.
Satz Taster.
Jeu de palpeurs.
Juego palpadores.



G1000A65 (1 x kit) G1000A65K (5 x kit)

Protezione supporto utensile superiore.
Protection for upper tool support.
Satz oberer Montagevorrichtung-Schutz.
Protection support outil supérieur.
Protección para util superior.



G1000A66K (5 x kit)
Protezione cono di bloccaggio.
Set of protections of locking cone.
Satz Spannkone Schutz.
Kit protections cône dispositif de blocage.
Juego protecciones cono dispositivo de bloqueo.

G1000A68

Utensile di montaggio inferiore.
Lower tool.
Untere Montagekopf.
Outil inférieur.
Util inferior.



G1000A116

G1000A90K

G1000A116

Utensile superiore predisposto per protezione G1000A90K (protezione non inclusa).
Upper tool for protection G1000A90K (protection not included).
Obere Montagekopf einsatzbar mit Kunststoffschutz G1000A90K (Montagekopfkunststoffschutz nicht im Lieferumfang).
Outil supérieur predisposé pour protection G1000A90K (protection pas incluse).
Util superior predispuerto para protección G1000A90K (la protección no está incluida).

G1000A90K (50 X kit)

Protezione per G1000A116.
Rim protection for tool G1000A116.
Montagekopfkunststoffschutz für G1000A116.
Protection pour G1000A116.
Juego protecciones p/uña G1000A116.



G1000A114

Utensile superiore comprensivo di supporto 710011691.
Upper tool including tool support 710011691.
Oberes Montagewerkzeug mit Werkzeughalter 710011691.
Outil supérieur avec support 710011691.
Util superior completo de soporte 710011691.



G1000A80 G1000A80/S

Bloccaggio rapido.
Quick locking.
Schnellspannung.
Blocage rapide.
Bloqueo rapido.



G1000A84K (5 x kit) (→ G1000A80)

Protezione cono di bloccaggio.
Set of protections of locking cone.
Satz Spannkone Schutz.
Kit protections cône de blocage.
Juego protecciones cono.



G1000A70K (5 x kit)

Protezione trascinato.
Set of protections for lug nut pin.
Satz Schutz Zugvorrichtung.
Kit protections dé d'entraînement.
Juego protecciones arrastrador.



G1000A81K (10 x kit)

Protezione ruote rovesce in gomma.
Set of rubber protections for support plate.
Satz Scheiben-Schutz (Gummi).
Kit protections plateau en caoutchouc.
Juego protecciones platillo de goma.

Helper

Dispositivo premitallone rotante pneumatico.
Rotating arm with pneumatic bead pushing device.
 Drehender pneumatischer Wulstniederhaltearm.
Bras pousse-talon rotatif pneumatique.
 Brazo prensa talón rotatorio neumático.



**PLUS91 AKC
PLUS91 AKL**



G800A58
 (→ PLUS91AKC + G1000A111)
 (→ PLUS91AKL + G1000A111)
 Trazione per premitallone rotante.
Traction for rotating bead pushing device.
 Zugvorrichtung für den Hilfsmontagearm.
Traction pour pousse-talon rotatif.
 Tracción para prensa talón rotatorio.



STANDARD



WDK



G1000A111
 (→ PLUS92, PLUS 93, PLUS 96,
 PLUS 91 AKC, PLUS 91 AKL)
G1000A119
 (→ PLUS 94)
 Pressore sagomato WDK.
WDK bead pressure device.
 WDK-Adapter.
Outil de pression WDK.
 Prensa talón WDK.



PLUS 94



PLUS 92



PLUS93 - PLUS96



G1100A2

PLUS80 CL PLUS80 CL/M

Dispositivo premi-alza tallone pneumatico.
Air-driven device for bead pushing-raising.
 Pneumatischer Hilfsmontagearm.
Dispositif pousse-lève talon pneumatique.
 Dispositivo prensa-levanta talón neumático.



G1000A7
 Rullino premitallone.
Bead pushing roller.
 Wulstniederhalte Rolle.
Rouleau pousse-talon.
 Rodillo prensa talón.

G1000A53
 Leva alzatalone inferiore.
Lower lever.
 Unteres Montiereisen.
Levier inferieure.
 Palanca inferior.

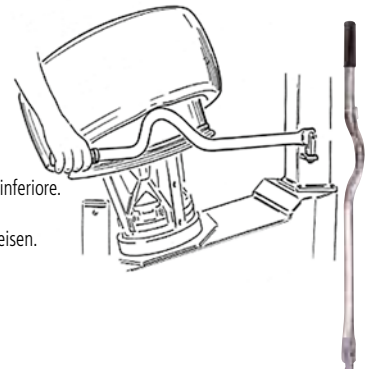

Magic Cord

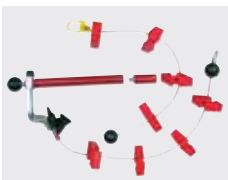

G1000A67 - 28"

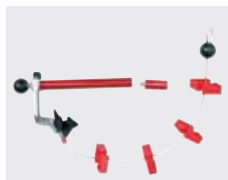

G1000A56 - 22"

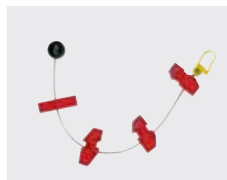

G1000A36 (→ G1000A56)
 Extension (22" - 28")



Premitalone con trazione.
Bead pushing device with pulling system.
 Wulstboy mit Zugvorrichtung.
Pousse-talon avec traction.
 Prensa talón con tracción.

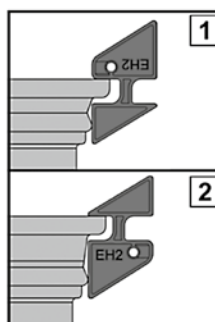

Lato 1 per cerchi normali con balconata corta.
Side 1 for standard rims with short balcony.
 Site 1 für Standardfelgen mit Kurzem Humb
Côté 1 pour jantes standard avec rebord court
 Lado 1 para llantas normales con espesor reducido

Lato 2 per cerchi EH2 / EH2+ con balconata lunga.
Side 2 for EH2 / EH2+ rims with long balcony.
 Seite 2 für EH2 / EH2+ Felgen mit Langem Humb
Côté 2 pour jantes EH2 / EH2+ avec rebord long
 Lado 2 para llantas EH2/EH2+ con espesor largo



Adattatori bloccaggio centrale / Center locking adapters



G1000A87 (5 x h=70 mm)
Flangia universale per ruote rovesce.
Universal flange for reverse rims.
Universalfansch für Felgen mit versetztem Tiefbett.
Bride universelle pour roues à gorge renversée.
Garra universal para ruedas invertidas.



G1000A72 (5 x h=70 mm)
Flangia universale per ruote senza foro centrale e adatta anche a ruote rovesce.
Universal flange for closed centre, adapted also for reverse rims.
Universalfansch für Räder ohne Mittelloch, geeignet auch für Felgen mit versetztem Tiefbett.
Bride universelle pour roues sans trou central, indiquée aussi pour roues à gorge renversée.
Brida universal para ruedas sin agujero central (llantas ciegas) y indicada para ruedas invertidas.



G1000A102 (5 x h=110 mm)
(→ G1000A72, G1000A87)
5 colonnette da 110 mm per ruote rovesce.
5 stud kit 110 mm long for reverse rims.
Satz Bolzen 110 mm für Felgen mit versetztem Tiefbett.
5 doigts de 110 mm pour jantes renversée.
5 espárragos largo 110 mm para ruedas invertidas.

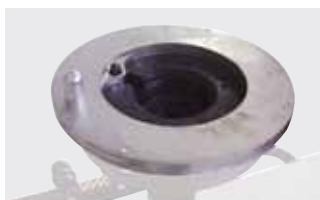

G1000A101
Flangia per autocarri leggeri.
Flange for light trucks.
LLKW-Flansch.
Flasque pour utilitaires.
Garra para camiones ligeros/furgonetas.



G1000A123
Flangia universale per bloccaggio ruote attraverso i fori di fissaggio.
Universal flange for clamping wheels through locking holes.
Universaltypenflansch mit Bolzenfixierung.
Flasque universelle pour blocage de roue par les trous de fixation.
Garra universal para bloqueo de rueda a través de los agujeros de fijación.



G1000A92
G1000A126
G1000A92 - Ø 50 mm
G1000A126 - Ø 69 mm
Cono per albero D.40 con distanziale.
Cone for D.40 shaft with spacer.
Konus für 40-er Welle mit Distanzring.
Cône avec cale pour arbre diam.40.
Cono para eje D.40 con espesor.



G1000A125
Adattatori moto.
Bike adapters.
Motorradspannvorrichtung.
Motos adaptateurs.
Adaptadores de motos.



Accessori bloccaggio a tulipano / Tulip clamping accessories



G1000A19
Set coperture in ferro per tamponi.
Steel rim adapter.
Stahlfelgenadapter.
Adaptateurs pour jantes en tôle.
Adaptadores para llantas de hierro.



G1000A20
Kit griffe EVO 17,5" (per trasporto leggero).
External jaws for 17.5" light truck.
17,5" LLKW-Spannbacken.
Adaptateurs pour jantes VUL 17,5" en tôle.
Adaptadores llantas hierro 17,5".



G1000A75
Flangia EVO 17,5".
Flange EVO 17,5".
Flansch EVO 17,5".
Flasque EVO 17,5".
Garra EVO 17,5".



G1000A18
Kit moto.
Motorcycle Kit.



G1000A21
Appoggio ruote registrabile.
Adjustable wheel support with threaded connection.
Einstellbarer Radhalter mit Gewinde.
Appui roue réglable attache à vis.
Soporte rueda regulable con enganche-tornillo.



G1000A45
Kit di bloccaggio per ruote rovesce >20".
Kit for clamping reverse rims >20".
Spannsatz für umgedrehte Räder >20".
Kit dispositif pour roues renversées >20".
Dispositivo de bloqueo para ruedas invertidas >20".



G1000A42
Dispositivo di sicurezza con supporto.
Safety kit with support.
Satz Sicherheitsvorrichtung mit Halterung.
Kit dispositif de sécurité avec support.
Juego dispositivo de seguridad con soporte.

Generatore di azoto Nitrogen generator



G1000A48
G1000A50
Generatore di azoto con vaschetta portaoggetti.
Nitrogen generation integrated in storage tray.
Stickstoffgenerator im Ablagefach eingebaut.
Générateur d'azote intégré dans la bac porte-outils.
Generador de nitrógeno integrado en el contenedor porta objetos.

Dispositivi di gonfiaggio Tyre inflation devices



G1000A46
Gonfiatore elettronico digitale con vaschetta porta-oggetti integrata.
Montaggio in fabbrica.
Automatic digital inflator with tool box. Factory installed.
Digitaler automatischer Reifenfüller. Werksseitig montiert.
Dispositif de gonflage digital automatique avec casier. Monté en usine.
Inflador digital automático con caja incluida. Montado en fabrica.

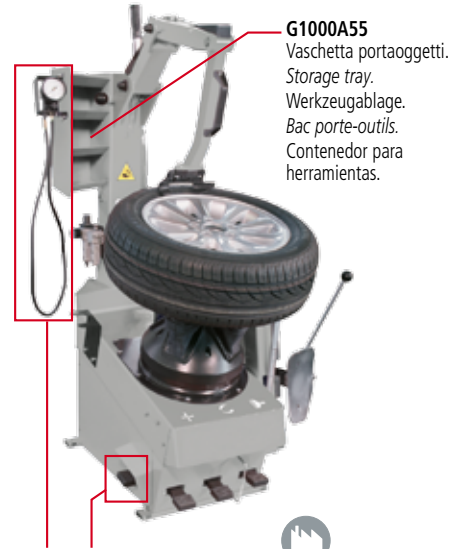

G1000A51
Variante gonfiaggio con comando a pedale, manometro e valvola bilanciatrice.
Assemblaggio in fabbrica.
Pedal activated inflator, gauge and balancing valve. Factory installed.
Pedalgesteuerter Reifenfüller mit Manometer und Druckregler. Werksseitig montiert.
Variante gonflage commande à pédale, manomètre et valve de dosage. Monté en usine.
Suplemento para inflado con mando a pedal, manómetro y válvula repartidora. Montado en fabrica.

Vari / Various



G800A38
Pennello.
Brush.
Schmierpinsel.
Pinceau.
Brocha.
G108A16
Pennello angolare in legno.
Angular wooden brush.
Holz-Schmierpinsel.
Pinceau angulaire en bois.
Brocha profesional de madera.



G800A37 (3,5 kg / 8lbs)
Pasta di montaggio.
Mounting grease.
Montagepaste.
Pâte de montage.
Jabón profesional.

NOTE:
8 x carton
160 x pallet



G1000A95
G1000A96
Vaschetta portaoggetti.
Storage tray.
Werkzeugablage.
Bac porte-outils.
Contenedor para herramientas.



G1000A115
Limitatore corsa stallonatore.
Bead-breaker stroke limiter.
Abdrückschaufelbegrenzer.
Limiteur de course détalonneur.
Limitador de carrera destalonador.



G1000A121
Per ampliare il campo di lavoro fino a 28".
To expand the working range up to 28".
Um den Arbeitsbereich bis 28" zu erweitern.
Pour étendre le champ de travail jusqu'à 28".
Para ampliar el campo de trabajo hasta 28".



G1000A107
G1000A118
Rullo Matching
Matching Roller

G1000A86 **G1000A109**
Specchio / Mirror / Spiegel
Mirroi / Espejo.

Wheel lift

Sollevatore pneumatico ruote.
Pneumatic wheel lift.
Pneumatischer Radheber.
Élévateur pneumatique de roue.
Elevador neumático ruedas.



G1000A122



G1000A99
G1000A108
G1000A120
G1000A129



Cinghia / Belt

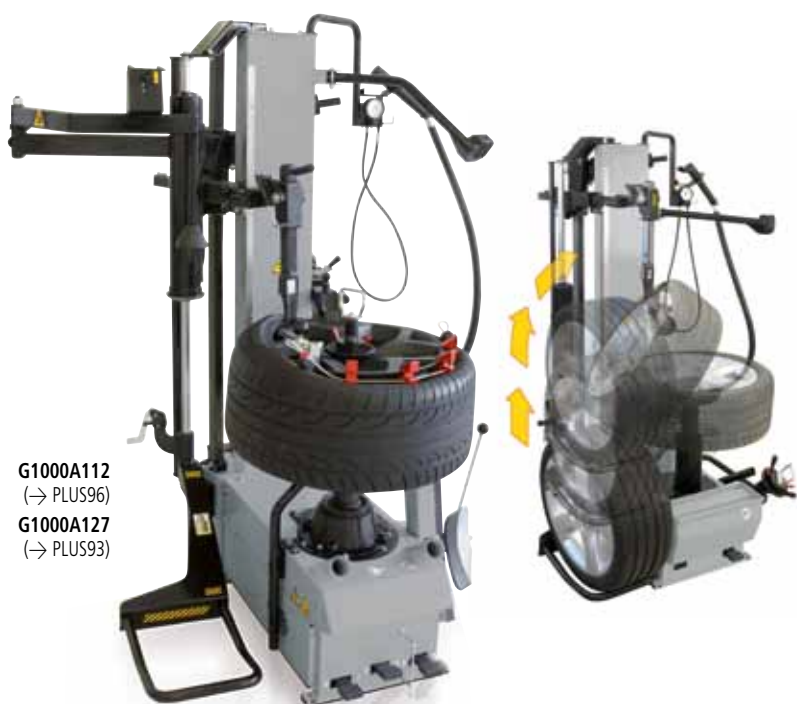

G1000A112
(→ PLUS96)
G1000A127
(→ PLUS93)



G1000A40

G1000A8

Kit cinghia inserisci tallone.
Belt kit for bead insertion.
Montage Gurt.
Kit sangle pousse-talon.
Juego cinturón para fácil puesta del talón.



Quando la ruota gira, la cinghia tira il tallone nel canale per facilitare il montaggio.

When rotating the wheel, the belt pulls the bead into the drop center to allow easy mounting.

Beim Radumdrehen zieht der Gurt die Wulst ins Felgenbett und erleichtert die Montage.

Avec la rotation de la roue, la sangle tire le talon dans le creux de jante et facilite le montage.

Quando la rueda da vueltas, el cinturón empuja el talón en la garganta y facilita el montaje.

Utensili / Tools



G1000A14

Utensile in plastica auto.
Car plastic tool.
PKW-Kunststoffmontagekof.
Tête en matériel synthétique VL.
Útil en plástico turismos.



G1000A15

Utensile in plastica moto.
Motorbike plastic tool.
Motorrad-Kunststoffmontagekof.
Tête en matériel synthétique moto.
Útil en plástico motos.



G1000A23

Moltiplicatore di forza.
Force multiplier.
Montagekopf-Kraftverstärker.
Multiplicateur de force.
Multiplicador de fuerza.



G1000A128

Dispositivo registrazione altezza utensile.
Device for adjusting tool height.
Höheneinstellvorrichtung des
Montagewerkzeugs.
Dispositif pour l'enregistrement de l'hauteur
de l'outil.
Dispositivo de regulación de altura del útil.



G1000A29

Braccio con attacco rapido.
Quick change shaft and tool.
Schnellsteckvorrichtung.
Kit de remplacement rapide
de la tête.
Conexión rápida para útil.

Leva Alzatalloni / Bead Levers



G1000A11

Leva alzatallone arcuata.
Half moon bead lever.
Halbmondmontiereisen.
Levier demi-lune.
Palanca levanta-talón en forma de "plátano".



G1000A52

Leva alza tallone standard.
Standard bead lever.
Standardmontiereisen.
Levier standard.
Palanca levanta talón estándar.



G1000A54

Porta leva extra.
Bead lever support kit.
Montiereisenhalter.
Kit porte-levier.
Juego porta palanca.

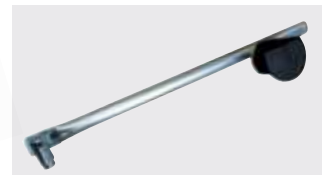

G1000A24

Leva matching.
Matching rod.
Satz Matching.
Kit matching.
Juego para matching.

Protezioni / Protections



G100012K (50 x kit)

(→ G1000A14)
Protezione cerchi per utensile di montaggio.
Rim protection for mounting head.
Montagekopfschutz.
Protection de roues pour tête de montage.
Protección llantas para útil de desmontaje.

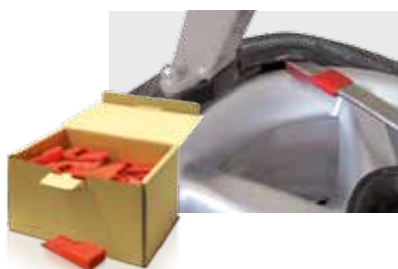

G1000A13K (50 x kit) (→ G1000A11 - G1000A52)

Confezione protezioni leva alzatalloni.
Bead lever protection package.
Satz Montagehebel-Alufelgenschutz.
Boîte de protections levier.
Confección protecciones palanca.



G1000A100K (50 x kit)

Confezione di protezioni tallone RFT (direttiva WDK).
Bead protections for RFT (WDK standard).
WDK-Kit.
Boîte de protections talon RFT (norme WDK).
Juego de protecciones talón ruedas RFT (norma WDK).



G800A32

Protezione tallone per pneumatici "Run Flat".
Run Flat bead protection.
Felgenhornwulstschutz für "Run Flat-Reifen".
Protection talon pour pneus "Run Flat".
Protección talón para neumáticos "Run Flat".



G800A11

Protezione paletta stallonatore.
Bead breaker blade protection.
Abdrückschaufelschutz.
Protection détalonneur.
Protección paleta destalonadora.
G800A11K - Kit 5 x G800A11

